



DEPARTMENT OF COMMUNITY DEVELOPMENT SERVICES

Economic Development Division

m e m o r a n d u m

TO: Laurel Lunt Prussing, Mayor

FROM: Elizabeth H. Tyler, FAICP, Director, Community Development Services

DATE: June 11, 2013

SUBJECT: **A Resolution Authorizing and Approving an Addendum to the Public Art Design Services Agreement with Preston Jackson of April 15, 2013**

Introduction and Background

For a number of years it has been a goal of the Public Arts Commission to create a lasting piece of public artwork to commemorate the life and legacy of Dr. Martin Luther King, Jr. in King Park. The completed artwork will help promote the park as an amenity for the local neighborhood and school, as well as provide an attraction for residents of Urbana and Champaign County.

City staff and the King Park Public Art Project Commission subcommittee worked with the Urbana Park District to identify a qualified artist to design public art in the park through a Request for Qualifications (RFQ) process. After the originally selected artist requested to withdraw from the project, Preston Jackson, a visual artist from Illinois, was selected by the Public Arts Commission at their February 12, 2013 meeting as the new artist to design a public art piece for King Park. Based in Peoria, IL, Mr. Jackson is an accomplished artist who has produced many public art pieces for cities in Illinois and has taught at the School of the Art Institute of Chicago, Bradley University, and Millikin University. His work has particularly dealt with history and the African-American experience. Mr. Jackson has worked extensively with cities in Illinois, all of whom provided extremely positive references.

An agreement with Mr. Jackson outlining the scope of his design services, including deliverables, schedule of performance, schedule of compensation, and process of design approval, was negotiated by City staff. This agreement was written to ensure the creation of a project that meets the following Program Goals, as outlined in the original RFQ:

- Beautify and improve King Park and the city streetscape
- Honor the legacy of Dr. Martin Luther King, Jr.'s work and ideas.

- Integrate public art into the neighborhood and park environment, creating a sense of place and purpose, and promoting tourism and commerce.
- Beautify and improve the city streetscape.
- Preserve and commemorate local and multicultural traditions and histories.
- Provide opportunities for local and national, established and emerging artists in Urbana and Champaign County.
- Enrich the lives of Urbana residents and visitors.

Following approval by the Public Arts Commission at their April 2, 2013 meeting, this Public Art Design Services Agreement (Exhibit B) was approved by City Council at the April 15, 2013 meeting. A budget amendment for an additional \$30,000 for the project from TIF 3 funds was also approved by City Council at this meeting. This raised the overall project budget to \$80,000, all from TIF 3 funds which must be used by December 31, 2013 when the TIF district expires.

Discussion

Following the execution of the Public Art Design Services Agreement, Preston Jackson and his assistant, Joy Kessler, traveled to Urbana on Thursday, April 25, 2013. They met with the City Public Arts Coordinator and Tim Bartlett, Urbana Park District Superintendent of Operations and Planning at the King Park site. Additionally, a neighborhood meeting was held at the Urbana Park District Operations and Planning Office located at 1011 E Kerr Ave from 5:30 to 8:00 PM. The meeting was attended by representatives the City of Urbana, the Urbana Park District, the Urbana Public Arts Commission, King School, Adopt-A-Park, the Jettie Rhodes Day Committee, and other community members (Exhibit C). Mr. Jackson presented images of his public art work located throughout Illinois, including pieces located at the Douglas Branch Library in Champaign and on the University of Illinois campus (Exhibit D.) He then showed some sketches of his ideas for the King Park sculpture to the group for feedback. The assembled group had a few suggestions. Scott Rhodes commented that he was disappointed that Dr. King was not depicted in these sketches for the sculpture. Unfortunately, due to the policies of the King Foundation related to the use of their intellectual property and project budget limitations, Dr. King's image or quotes cannot be used in this piece of public art. Maryam Ar-Raheem, another community member attending the meeting, responded that because Dr. King was a humble man, he might not like his image being used in sculptures.

As outlined in Exhibit A: Design Services & Deliverables of the Public Art Design Services Agreement (Exhibit B), Mr. Jackson submitted a preliminary concept that was reviewed by the King Park Public Art selection committee on May 3, 2013. Similar to the sketches he showed at the meeting on April 25, the sculpture depicted in this preliminary concept would be fabricated of stainless steel and bronze, standing 12 feet tall. Showing elements of the history of the Civil Rights Movement and Dr. King's work in bronze, the larger base of the sculpture would be stainless steel. Such artistic depictions of history will appeal to residents and visitors of all ages, creating an asset for the neighborhood and Urbana and honoring the legacy of Dr. Martin Luther King, Jr. The committee was supportive of this concept and recommended it be presented to the Public Arts Commission for approval.

The Public Arts Commission approved Preston Jackson's preliminary concept at the May 14, 2013 meeting. Following this approval, as outlined in the King Park Public Art Design Services Agreement, Preston Jackson submitted a Final Design for City approval. This Final Design (Exhibit E) is a more complete version of the preliminary concept approved by the Commission, and outlines every physical feature of the construction of the Artwork and its integration with the site. Viewing the drawings with images of Mr. Jackson's other work (Exhibit D), makes it easier to envision what the finished piece will look like. This final design also includes a narrative describing the inspiration and themes of the work, the fabrication schedule, the maintenance requirements, and the project budget. The Final Design was reviewed by City and Urbana Park District staff and approved by the Urbana Community Development Services Director, according to the procedure outlined in the King Park Public Art Design Services Agreement (Exhibit B).

Following this approval, City staff has worked with the artist to negotiate an Addendum to the King Park Public Art Design Services Agreement of April 15, 2013 (Exhibit A). This addendum commissions the fabrication of the artwork depicted in the final design (Exhibit E) submitted by Preston Jackson and approved by City Staff. It agrees that the artist will fabricate the sculpture as outlined in the final design, outlines the delivery of the artwork to the City, and includes a project payment schedule. It warrants that the artwork shall be a unique and original product of the artist and transfers the title to the artwork from the artist to the City or its assignee. It outlines a schedule of compensation, as well as the project budget and installation details. As it is an addendum to the original agreement, other than any changes or amendments it sets forth, all of the provisions in the agreement (Exhibit B) remain in full force and effect. The Urbana Park District has committed to handling physical installation of the finished piece in King Park, as well as building an earth berm to raise the sculpture up. This assistance allows for more of the limited budget to be used to create a larger piece. City staff is working with Urbana Park District staff on an agreement to transfer the title of the finished artwork from the City to the Urbana Park District. The Public Arts Commission reviewed Exhibit A at their June 13, 2013 meeting and unanimously voted it be forwarded to City Council for approval (Exhibit F).

Fiscal Impact

Of the \$80,000 budget for the King Park project, \$5,000 was spent on design development fees for the original artist who withdrew from the project. From the \$75,000 that remained, \$6,000 has now been paid to Preston Jackson for his design services as outlined in the King Park Public Art Design Services Agreement (Exhibit B).

The budget from the Final Design (Exhibit E) submitted by Mr. Jackson outlines the spending of the remaining \$69,000 allocated to this project. The Urbana Park District has committed to physical installation of the finished piece and site preparation, including the creation of an earth berm. No additional expenditures will be required. The funding source for this project is the TIF 3 district, which will expire on December 31, 2013. All funds committed to the King Park project must be spent by this date.

Options

1. Approve the attached resolution.
2. Approve the resolution with changes. It should be noted that any changes will need to be agreed upon by the parties involved.
3. Deny the resolution.

Recommendation

Staff recommends that the City Council approve the attached Resolution Authorizing and Approving an addendum to the Public Art Design Services agreement with Preston Jackson of April 15, 2013 (Exhibit A).

Prepared by:

Christina McClelland, Public Arts Coordinator

Attachments:

- Exhibit A: A Resolution Authorizing and Approving an Addendum to King Park Public Art Design Services Agreement of April 15, 2013 with attached Addendum
- Exhibit B: King Park Public Art Design Services Agreement
- Exhibit C: April 25, 2013 Neighborhood Meeting Sign In Sheet
- Exhibit D: Images of Preston Jackson's Public Art
- Exhibit E: Preston Jackson King Park Public Art Final Design
- Exhibit F: Draft Minutes from the June 11, 2013 Urbana Public Arts Commission Meeting

RESOLUTION NO. 2013-06-028R

A RESOLUTION AUTHORIZING AND APPROVING AN ADDENDUM TO THE PUBLIC ART DESIGN SERVICES AGREEMENT WITH PRESTON JACKSON OF APRIL 15TH, 2013.

NOW, THEREFORE, BE IT RESOLVED BY THE CITY COUNCIL OF THE CITY OF URBANA, ILLINOIS, as follows:

Section 1. That an Addendum to the Agreement Between the City of Urbana, Illinois, and Preston Jackson, in substantially the form of the copy of said Addendum attached hereto and hereby incorporated by reference, be and the same is hereby authorized and approved.

Section 2. That the Mayor of the City of Urbana, Illinois, be and the same is hereby authorized to execute and deliver and the City Clerk of the City of Urbana, Illinois, be and the same is authorized to attest to said execution of said Addendum as so authorized and approved for and on behalf of the City of Urbana, Illinois.

PASSED by the City Council this ____ day of _____, 2013.

AYES:

NAYS:

ABSTAINS:

Phyllis Clark, City Clerk

APPROVED by the Mayor this ____ day of _____, 2013.

Laurel Lunt Prussing, Mayor

Attachments: Exhibit A: Addendum to King Park Public Art Design Services Agreement of April 15, 2013

ADDENDUM TO PUBLIC ART DESIGN SERVICES AGREEMENT
OF APRIL 15TH, 2013.

WHEREAS, The City of Urbana, and Preston Jackson (hereinafter sometimes “Artist”) previously entered into an Agreement for Public Art Design Services on the 15th day of April, 2013, which Agreement addressed the design phase for a new sculpture piece to be placed in Martin Luther King Park (hereafter “Agreement”), in which the services of Artist is described in more detail in the exhibit setting forth the sculpture services and deliver those attached to the Agreement, and

WHEREAS, paragraph 6 of the Agreement provides that upon approval of the final design by the Director of Community Development Services, the parties shall negotiate an addendum to address commissioning the fabrication of the final design art work in which to reduce their Agreement to writing.

NOW THEREFORE IT IS AGREED between the parties as follows:

1. Artwork. Artist shall perform all work necessary to fabricate a steel and bronze sculpture piece in accordance with the specifications set forth in Attachment A to the Addendum.
2. Artist shall deliver the finished sculpture to the City at the location in Urbana, Illinois, designated by the City.
3. Payment. The City shall pay the sum of \$69,000.00 to the Artist for the art work pursuant to the following schedule:
 - a. \$ 23,000.00 upon signing of the Agreement. The Artist shall commence work on the Artwork immediately upon receipt of the first payment.
 - b. \$ 23,000.00 upon approval by the Director of Community Development Services of the completed wax pattern of the cast bronze portion of the monument of the proposed piece by the City, which shall be accomplished in time sufficient for the Artist to complete the Artwork as scheduled.
 - c. \$ 23,000.00 upon Artist’s delivery of the Artwork to the City.

4. The parties acknowledge that the funding for this project is from Tax Increment Financing (TIF). The TIF funding source is no longer available after December 31, 2013. In the unlikely event that, for any reason it appears likely that the sculpture piece will not be delivered by December 31, 2013, as provided for herein, the Mayor of the City of Urbana is authorized to negotiate and agree to any amendments needed to complete the project.

5. Warranty. The Artist warrants that the Artwork shall be a unique and original product of the Artist's creative efforts, that there will be only one edition except as specified herein or by other written Agreement of the Parties, and that the Artwork has not been accepted for sale elsewhere.

6. Transfer of Title. The Artist agrees to transfer all right, title and interest in the artwork to the City, or its assignee upon receipt of the final payment as provided above. However, the Artist shall retain the right to produce photographs of the artwork for any legitimate purpose.

7. Since this is an Addendum to the Agreement, other than in any regard that this Addendum specifically and expressly changes or amends any other terms of the Agreement, all of the rights, obligations of the parties set forth in the Agreement shall remain in full force and effect.

CITY OF URBANA, ILLINOIS

ARTIST

By: _____
Laurel Lunt Prussing, Mayor

By: _____
Preston Jackson

Dated: _____

Dated: _____

ATTEST:

Phyllis D. Clark, City Clerk

Dated: _____

ATTACHMENTS:

ATTACHMENT A: KING PARK PUBLIC ART FINAL DESIGN

Public Art Design Services Agreement

This **AGREEMENT FOR PUBLIC ART DESIGN SERVICES** (together with all Exhibits, hereinafter the "Agreement") is made and entered into as of this ____ day of ____, 2013, by and between the CITY OF URBANA, (hereinafter the "City", an Illinois municipal corporation whose principal office is located in Champaign County, Illinois and Preston Jackson (hereinafter the "Artist") whose principal office is located at 11320 N Hickory Woods Court, Dunlap, IL 61525.

WITNESSETH:

WHEREAS, the City Council has determined that it is in the public interest to support public art; and

WHEREAS, the City desires to obtain public art design services in connection with the development of a design for public art elements to be installed at King Park ("site"); and

WHEREAS, Artist is in the business of creating original works of art; and

WHEREAS, the Artist was selected by the City through a Request for Qualifications process by the City to design and develop public art elements for the Project; and

WHEREAS, the City desires to enter into an agreement with Artist to fully develop a design of artwork in anticipation of fabrication and installation of it.

NOW, THEREFORE, in consideration of the above-stated premises and subject to the conditions hereinafter set forth, the parties agree as follows:

1. Scope of Services. The Artist shall provide design services (the "Services") and deliverables ("Deliverables") as set forth in Exhibit A, which is hereby incorporated by reference into this Agreement. The Services shall result in Deliverables embodying a final design (the "Design") including, but not limited to, a plan for fabrication and installation.

2. Schedule of Performance. The Public Art design services shall be completed and submitted within the time periods defined in the detailed Scope of Services attached as Exhibit A.

3. Extension of Time. The City agrees to grant extensions of time to the Artist in the event that there is a delay caused by the City, or pursuant to those circumstances set out in Section 20 of this Agreement. Extensions of time shall comply with the requirements of Section 18 of this Agreement.

4. Compensation. The City agrees to pay Artist \$6,000 as set forth in Exhibit B.

5. Representations and Warranties. Artist represents and warrants that the services rendered pursuant to this Agreement shall result in an original Design that, to the best of Artist's knowledge, does not infringe on any third party intellectual property rights. The City shall make available for Artist's examination and use all information regarding the Site and Project, including but not limited to: plans, specifications, reports, narratives, publications, statistics, records and other information pertinent to Artist's performance under this Agreement, at no cost to Artist. Where appropriate, the City shall direct their Design Team (ie. engineers, landscape architects, and other design professionals) to work in cooperation with Artist to fully develop the design and fabrication and/or installation plans for the Public Art. Further, the City shall provide its reviews and approvals of Artist's public art designs in a prompt and timely manner.

6. Design Approval Process. It is anticipated that the design and development approval process shall be in phases, all of which is more fully set forth in Exhibits A and B relating to "deliverables." The preliminary concept must be approved by the Urbana Public Arts Commission. Upon approval of the final design by the Community Development Services Director, the Urbana Public Arts Commission and the Artist shall negotiate an addendum to this Agreement to provide for commission and fabrication of the final piece. This addendum must be approved by the Urbana Public Arts Commission and the Urbana City Council.

7. Transfer of Title. Simultaneous with Artist's receipt of the final payment, Artist shall transfer title to the Deliverables to the City. The approved design concept submitted to the City under this agreement and the resulting Artwork will be the sole property of the City and subject to the provisions of the Visual Artists Rights Act of 1990. The design concept may be used for exhibition purposes.

8. Copyright Ownership. Artist retains all copyrights in the design and any plans, drawings, model, and the like prepared by the Artist pursuant to this agreement. The Artist is responsible, at his/her option, for registering any copyrightable material in his or her name with the U.S. Register of Copyrights, at no additional cost to Client.

9. Publicity and Public Information: The City may inform the general public about the Artwork by issuing news releases and news stories. In addition, the City may provide information to persons interested in learning more about the Artist. The City will have no liability for errors or omissions in any publications.

10. Motion Pictures, Television Productions, and Photographs: The Artist grants the City a perpetual license which allows, without limitation, the Artist's Artwork to be included in any motion picture, television production, photographs (to be used on the City website or in City promotional materials), taken at the Location, or in any other media promoting the City or its activities. No further and additional consideration shall be remitted to the Artist for said license. Such license grants to the City an irrevocable license to graphically depict the Work in any non-commercial manner whatsoever. For the purposes of this Agreement, the graphic depiction of the Work on materials

designed to promote the City or its services or shall be deemed to be non-commercial use. In addition, the Artist grants a perpetual license to the production company and/or photographer to exhibit all or any part of said film or photographs throughout the world. Such exhibitions will be for non-commercial purposes only and will credit the City as owner of the Work and Artist as creator of the Work.

11. Alterations of Site or Removal of Artwork:

- a. The City shall notify the Artist in writing upon adoption of a plan of construction or alteration of the Site which would entail removal or relocation of the Artwork which might result in the Artwork being destroyed, distorted or modified. The Artist shall be granted the right of consultation regarding the removal or relocation of the Artwork. If the Artwork cannot be successfully removed or relocated as determined by the City, the Artist may disavow the Artwork or have the Artwork returned to the Artist at the Artist's expense. If the City and Artist agree that the Artwork can be included in the alteration of the Site with modifications, parties agree to negotiate fair compensation for Artist's services to appropriately and adequately modify the Artwork to meet new site conditions.
- b. The Artwork may be removed or relocated or destroyed by the City pursuant to the Visual Artists Rights Act of 1990, should the Artist and the City not reach mutual agreement on the removal or relocation of the Artwork after a period not to exceed 90 days after written notice to the Artist. During the 90 day period, the Parties shall engage in good faith negotiations concerning the Artwork's removal or relocation.
- c. If the City reasonably determines that the Artwork presents imminent harm or hazard to the public, other than as a result of the City's failure to maintain the Artwork as required under this Agreement, the City may authorize the removal of the Artwork without the prior approval of the Artist.
- d. This clause is intended to replace and substitute for the rights of the Artist under the Visual Artists' Rights Act to the extent that any portion of this Agreement is in direct conflict with those rights. The parties acknowledge that this Agreement supersedes that law to the extent that this Agreement is in direct conflict therewith.

12. Indemnification.

- a. The Artist shall indemnify and hold harmless the City, its officers, and employees from and against any and all claims, actions, damages, fees, fines, penalties, defense costs, suits or liabilities which may arise out of any act, neglect, omission or default of the Artist arising out of or in any way connected with the Artist (or Artist's officers, employees, agents, volunteers and sub-contractors, if any) performance or failure to perform under the terms of this agreement.

- b. The City shall indemnify and hold harmless the Artist from and against any and all claims, actions, damages, fees, fines, penalties, defense costs, suits or liabilities which may arise out of any act, neglect, omission or default of the City arising out of or in any way connected with the City's (or City's officers, employees, agents, volunteers and sub-contractors, if any) performance or failure to perform under the terms of this agreement.

13. Independent Contractor. Artist is furnishing his/her services hereunder as an independent contractor, and nothing herein creates any association, partnership or joint venture between the Parties hereto or any employer-employee relationship.

14. Modification. Any modification of this Agreement shall be in writing and signed by all the parties.

15. Termination. Either party may terminate this Agreement effective on the 10th day after written notice is delivered to the other party delivered by certified mail or in person. Termination of this Agreement shall be without prejudice to any obligations or liabilities or either party accrued prior to such termination.

16. Death or Incapacity of Artist. Should the Artist become ill, disabled, injured, or otherwise incapacitated at any time between the execution of this Agreement and the date of completion, the Artist or one of his representatives will notify the City promptly. In the event of Artist's physical incapacity or death prior to the completion of the Agreement, all payments made up to the point of incapacity or death will be retained by Artist or Artist's estate and all work performed to date of incapacity or death will be compensated. If the Design is substantially completed and it is feasible for the work to be fully completed without undue delay, the City may elect to proceed under the terms of this Agreement with the written consent of Artist's estate. In the event that the City elects to proceed with the completion of the Design, and/or a commission of the Artwork, all remaining work to be completed in accordance with this Agreement will be delegated to Artist's studio personnel.

17. Force Majeure. The Parties will be excused from performing under this Agreement if performance is prevented by a condition beyond the control of the Parties such as acts of God, war, civil insurrection, government action or public emergency (but only for as long as such unforeseen occurrences exist). Both Parties will take all reasonable steps to assure performance of their contractual obligation when the unforeseen occurrences have ceased to exist, but resumption of performance will be subject to negotiation between the Parties if more than one (1) year has passed since either suspension of obligations under this Agreement or substantially changed circumstances.

18. Non-assignability. Artist will not assign, transfer or subcontract the creative and artistic portions of the Design or the Artwork to another party without the prior written consent of the City.

19. Severability. Each paragraph and provision of this Agreement is severable from the entire Agreement, and if any provision is declared invalid, the remaining provisions will remain in effect.

20. Compliance: The Artist agrees to abide by and be governed by all applicable federal, state, and local laws or regulations as said laws and regulations exist and are amended from time to time. Failure to comply with this provision will be considered a breach of this Agreement. In entering into this Agreement, City does not waive the requirements of any City or local ordinance or the requirements of obtaining any permits or licenses which are normally required to conduct business or activity contemplated by the Artist.

21. Jurisdiction and Venue. This Agreement will be governed by and construed in accordance with the laws of the State of Illinois, without reference to conflicts of laws principles. The parties hereby agree that the State and Federal Courts of Champaign County and the State of Illinois shall have exclusive jurisdiction to hear and determine any claims or disputes pertaining directly or indirectly to this Agreement or any matter arising therefrom or relating thereto. Each Party agrees to service of process through the procedure defined in Section 25.

22. Notices. All notices, requests, and reports required under this Agreement will be hand delivered or sent by certified mail as follows:

For Artist: Preston Jackson
11320 N. Hickory Woods Court
Dunlap, IL 61525

For the City: Public Arts Coordinator
Community Development Services
City of Urbana
400 S. Vine Street
Urbana, IL 61801

Notice is deemed to have been received either upon the date recipient signs the return certificate, or five (5) days after the notice is transmitted to recipient, whichever is sooner. A change in the designation of the person or address to which submittal, requests, notices and reports will be delivered is effective when the other party has received notice of the change by certified mail.

This provision is not applicable to "Deliverables" required under Exhibit A of this agreement, which may be provided electronically.

23. Dispute Resolution. In the event of any disputes arising from the terms of or performance under this Agreement, the parties shall first attempt resolution through good faith discussion and/or mediation. For disputes and differences of opinion

regarding aesthetic matters, the dispute will be presented to the Urbana Public Arts Commission for recommendation. If discussion and/or mediation do not resolve the dispute(s), the parties may resort to litigation and equitable relief to resolve disputes that still exist after good faith discussion and/or mediation. In addition, either party may seek equitable relief (injunction and/or specific performance) at any time when immediate enforcement or cessation of performance under this Agreement is required to avoid foreseeable damages to relief-seeking party's interests, including but not limited to intellectual property interests.

24. Entire Agreement. This Agreement constitutes the entire agreement between the parties and supersedes all previous agreements in this matter. There are no other written or oral agreements, representations or understandings with respect to the subject matter of this Agreement. This Agreement and its terms may be amended, modified, or waived only by written agreement, signed by both parties.

25. Non-waiver. No waiver will be binding on a party unless it is in writing and signed by the party making the waiver. A party's waiver of a breach of a provision of this Agreement will not be a waiver of any other provision or a waiver of a subsequent breach of the same provision.

26. Execution by Counterpart and Facsimile. This Agreement may be executed in counterpart and by facsimile.

THE PARTIES TO THIS AGREEMENT by their signatures acknowledge they have read and understand this agreement and intend to be bound by its terms.

CITY OF URBANA

By: _____

Jarrell Pruitt
MAYOR

Date: _____

4/17/13

ARTIST

By: _____

Roxton Jackson
ARTIST

Date: _____

ATTEST:

Shelley D. Clark
CITY CLERK

Date: _____

4/18/13

ATTACHMENTS:

EXHIBIT A: DESIGN SERVICES & DELIVERABLES

EXHIBIT B: PAYMENT SCHEDULE

EXHIBIT C: WORKERS' COMPENSATION

EXHIBIT D: PROJECT SCHEDULE

EXHIBIT A: DESIGN SERVICES & DELIVERABLES

DESIGN SERVICES

1. **Scope of Services.** The Artist will perform the following "Services", which include all other obligations required of the Artist by this Agreement, in a satisfactory and proper manner as determined by the City:
 - a. **Design/Consultation Services.** The Artist will work in collaboration with City staff, Urbana Park District staff, community stakeholders, and project personnel to gather information, share ideas, and identify themes or concepts for the for the **Martin Luther King, Jr. Park Public Art Project (the "Project")**. The Artist will conduct independent research as necessary to develop concepts and opportunities for the integration of artwork into the Project and will influence the overall Project design and strive to integrate art ideas into the Project. The Artist will work within the constraints of the right-of-way, easements, timeline and established project alignment to maximize resources wherever possible to impact the Project. The Artist will meet with the various community groups associated with the Project to listen to concerns, consider their interests, and gather Project information and foster communication. The Artist will develop a written description and appropriate visual materials to explain and illustrate the artwork concepts, site selections, and materials, which will comprise the artworks ("Work.")
 - b. **Approval.** The Work must be approved by the **Urbana Public Arts Commission**. The Artist will provide consultation through any City Department approval processes as may be required. Based on comments, the Artist will develop complete and detailed artwork proposal(s) that may be developed as stand-alone artworks.
 - i. Proposed works shall include:
 1. Detailed design drawing of the proposed artwork clearly indicating scale
 2. Written description of the artwork
 3. Written description of proposed materials with samples as appropriate
 4. Proposed artwork implementation budget.
 - ii. Artworks designed and fabricated by the Artist will be engineered and estimated through the Artist with the cost estimate including payment of all applicable local, state and federal taxes and costs of all labor and materials required to produce and install the artwork.
 - c. **Implementation of Designs.** Upon approval by the Urbana Public Arts Commission, an addendum for fabrication and installation of the Work by the Artist may be entered into following satisfactory completion of the Services under this Agreement.

DELIVERABLES

1. **Preliminary Concept:** Artist (in collaboration with City staff, Urbana Parks District Staff, and other design professionals as appropriate) shall submit to the City of Urbana a Preliminary Concept for the Artwork. The Artist will provide initial concepts, premises, themes, site selections and preliminary material considerations as products of this Phase. Such Concept Design(s) will be presented in reproducible format best suited to convey the concepts i.e. drawings, manipulated photographs, etc.

Preliminary Concept shall be submitted to the City of Urbana Public Arts Coordinator by April 29, 2013 for review by the King Park Public Art Project Committee and approval by the Urbana Public Arts Commission at their May 14, 2013 meeting.

2. **Final Design:** Artist (in collaboration with City staff, Urbana Parks District Staff, and other design professionals as appropriate) shall submit to the City of Urbana a Final Design for the Artwork detailing every physical feature of the construction of the Artwork and its integration with the Site.
 - a. Final Design shall include information sufficient to describe the Artwork in detail, including but not limited to:
 - i. Dimensioned drawings such as plan(s), section(s), elevation(s), site plans
 - ii. Structural considerations/engineer drawings for City staff or their designee to review
 - iii. Material samples
 - iv. Consultant reports/drawings/specifications if appropriate
 - v. Fabrication and installation budget, including artist fees
 - vi. Fabrication and installation schedule
 - vii. Installation narrative
 - viii. Maintenance requirements/instructions

Final Design shall be submitted to the City of Urbana Public Arts Coordinator no later than June 21, 2013 for review and approval by Community Development Services Director.

3. All deliverables will be provided in form easily printed and/or reproduced and suitable for distribution in 8 1/2" X 11" format. Deliverables can be made in hard copy print or electronic format (PDF or JPEG).

EXHIBIT B: PAYMENT SCHEDULE

1. Compensation and Method of Payment.

- a. **Compensation for Design Consultation Services and Purchase of Design:** For the Artist's Services, the City agrees to pay the Artist up to a total of Six thousand (\$6,000) ("Compensation"). The Compensation includes any applicable taxes, which must be paid by the Artist. The Compensation constitutes full and complete compensation for the Artist's Services under this Agreement. Artist agrees that payment is based on mutually agreed upon lump sums and not an hourly rate. The City shall pay Artist's invoices within sixty (60) days following receipt of invoice. Parties anticipate addendum for additional services of \$69,000 for commission and fabrication of artwork upon design approval.*
- b. **Method of Payment:** The Compensation will be paid to the Artist in the following installments within a reasonable period of time after completion of the Services described below:

2. Payment Schedule:

- a. One thousand Dollars (\$1,000) following City Council approval and execution of this Agreement ("First Payment");
- b. Three thousand Dollars (\$3,000) upon approval of Preliminary Concept by Urbana Public Arts Commission ("Second Payment");
- c. Two thousand Dollars (\$2,000) upon approval of Final Design by Community Development Director ("Final Payment");

*Payment for the addendum will be outlined in provisions of the addendum.

EXHIBIT C: WORKERS' COMPENSATION

1. Workers' Compensation:

Coverage A: Statutory Limits

Coverage B: One hundred thousand dollars (\$100,000) employer's liability limits for each accident or per disease, per employee. Said policies shall be endorsed to cover any disability benefits or Federal compensation acts if applicable.

2. If, however, the Artist does not have any employees as defined by state statutes and regulations and does not wish to cover himself or herself for Worker's Compensation, the Artist shall sign the following statement:

"I, do not have, nor intend to have for the full term of this Agreement, any employees. Furthermore, I do not wish to obtain or be covered under any Worker's Compensation insurance coverage and, therefore, am signing this statement in lieu of providing the above require Worker's Compensation coverage."

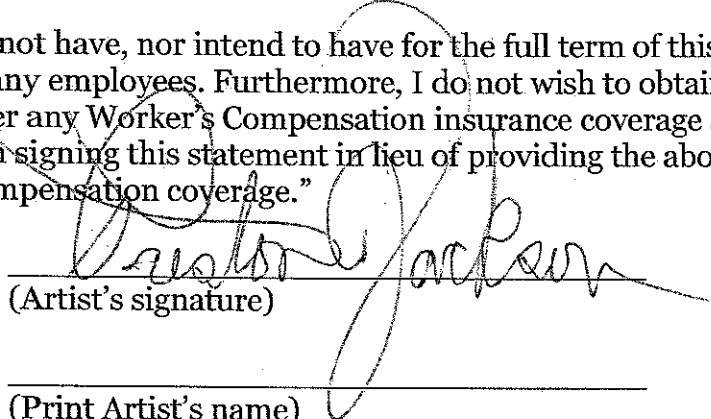

(Artist's signature)

(Print Artist's name)

EXHIBIT D: ANTICIPATED PROJECT SCHEDULE

1. **April 2, 2013:** Contract review and approval by Urbana Public Arts Commission
2. **April 15, 2013:** Contract review and approval by Urbana City Council
3. **April 15-26, 2013:** Artist initial trip to Urbana to meet with key stakeholders
4. **April 29, 2013:** Submittal of Preliminary Design to Public Arts Coordinator
5. **April 29-May 3, 2013:** Review of Preliminary Design by King Park Public Arts Project Committee
6. **May 14, 2013:** Approval of Preliminary Design by Urbana Public Arts Commission
7. **May-June 2013:** Submittal for Review and Approval of Final Design by Community Development Services Director
8. **July 9, 2013:** Approval of Addendum for Commission and Fabrication of Final Design by Urbana Public Arts Commission
9. **July 2013:** Approval of Addendum for Commission and Fabrication of Final Design by Urbana City Council
10. **July-September 2013:** Fabrication & Installation of Artwork
11. **December 31, 2013:** Installation of Artwork must be complete



Please Sign in

Name

E-mail

Add to Arts E-mail List?

Yuki Hayes	lmhayes@urbana-parks.org	already on
Tim Battalif	timbattalif@urbana-parks.org	on
Daniel R. Og	daniel.og@urbana-parks.org	yes
Eriniv Waaler	VWaaler@illinois.edu	on
Dan Wetankie Johnson		
Lashunda Cunningham	bbadie@gmail.com	yes
Scott Kroes	scottkroes@urbana.com	yes
Jennifer Lyons-Tatum	jlyons-tatum@uscd116.org	
MARLYN AR-KATHELY	mary-karambae@yahoo.com	no









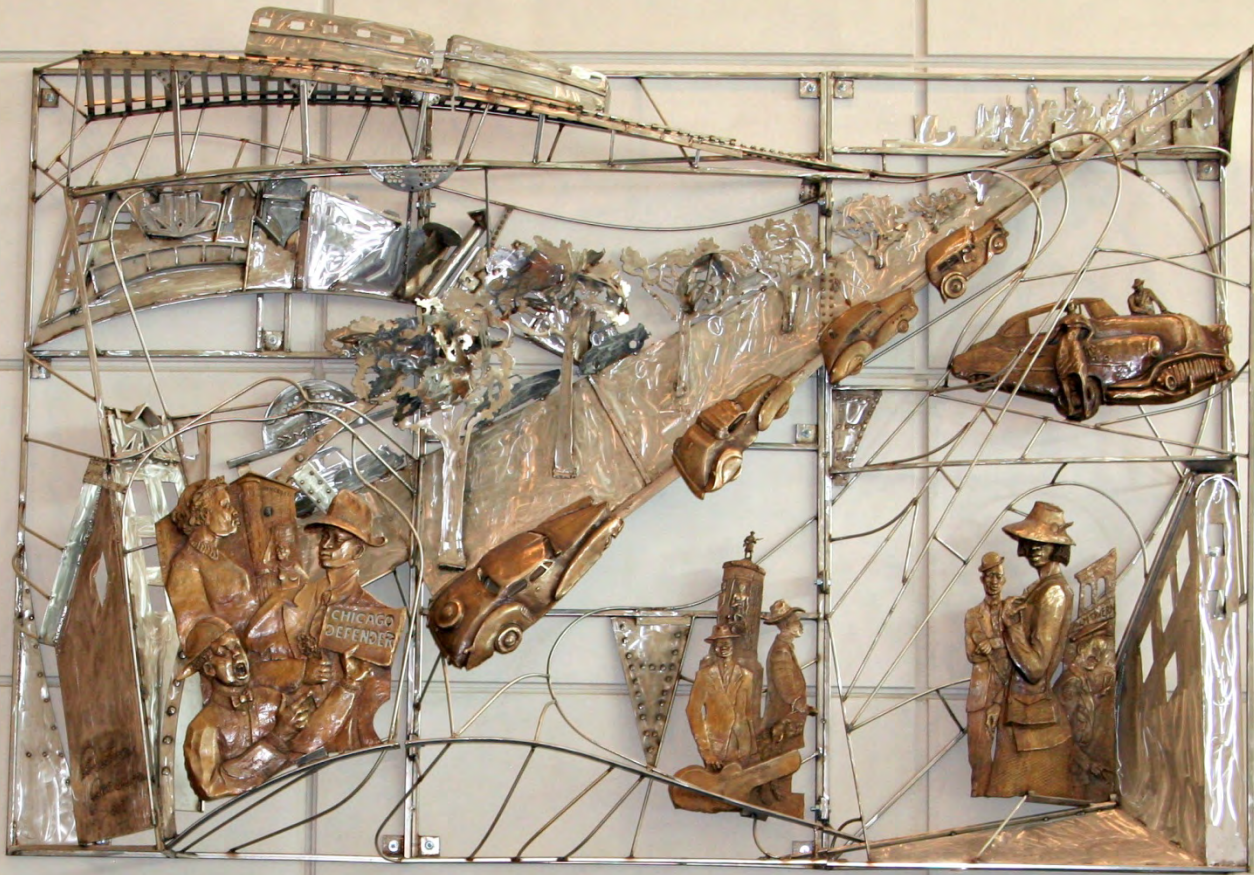

“Bronzeville, A Moment in Metal”

Cast Bronze Reliefs with
Stainless Steel



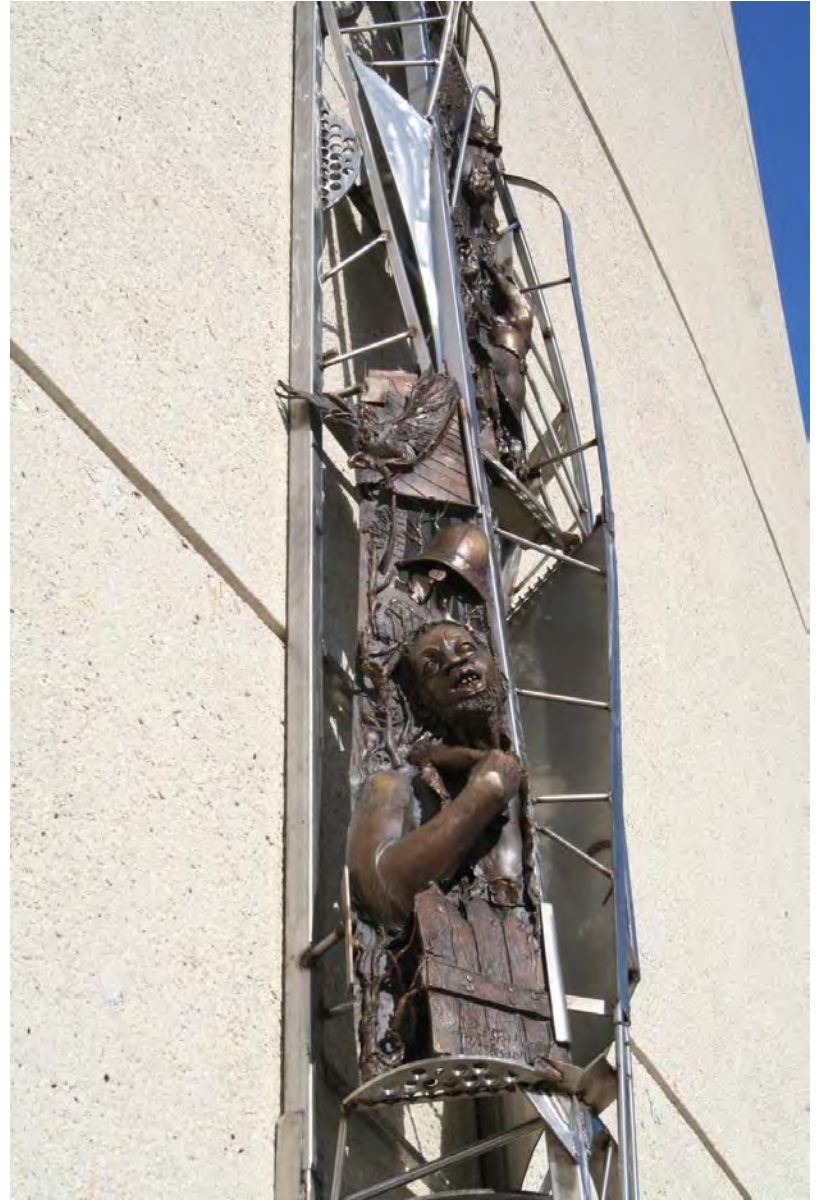

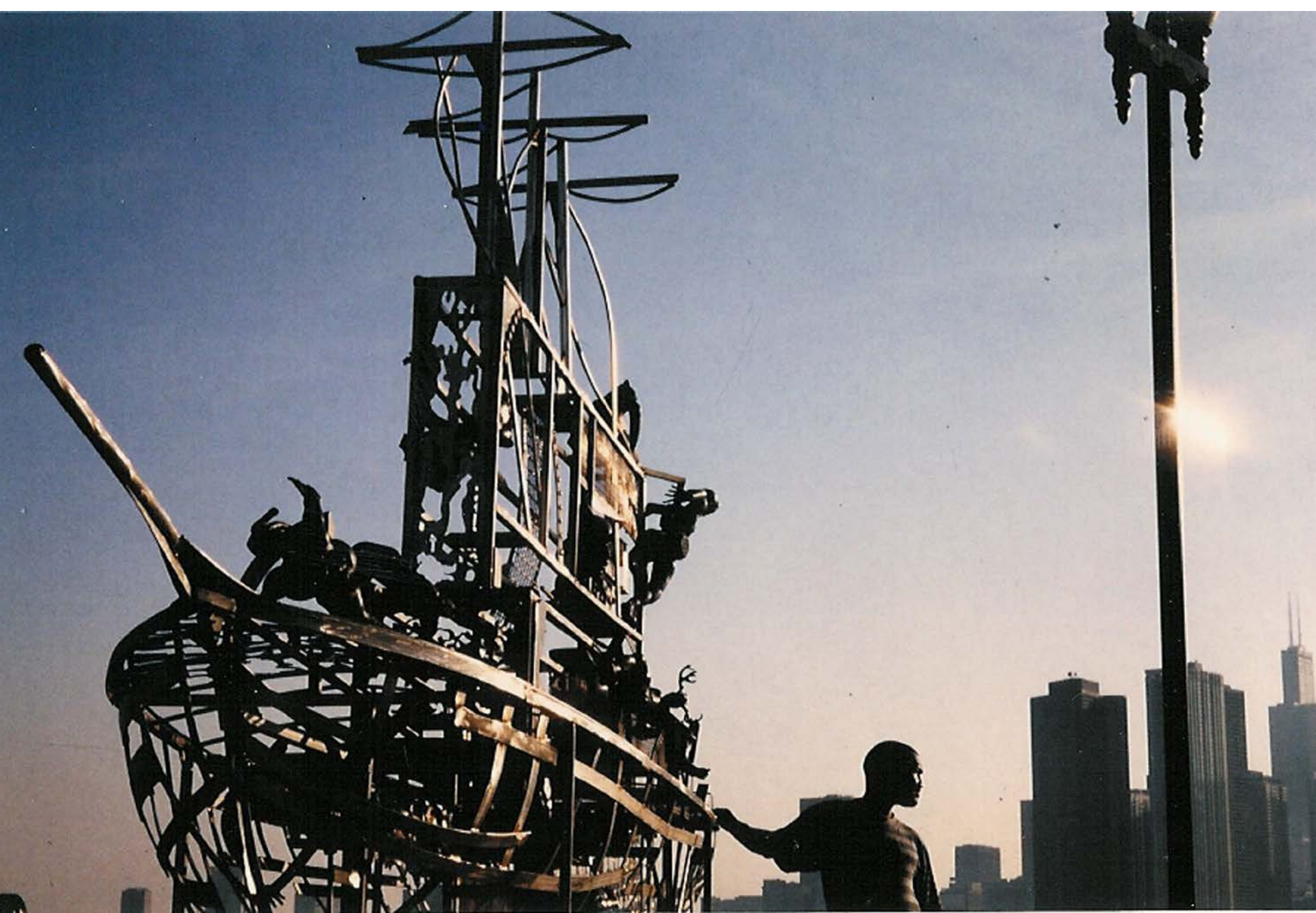



“From the
Cottonfield to the
Battlefield”

Cast Bronze Relief
on Granite



“Acts of Intolerance” Cast Bronze



**A MOUNDS
STORIC SITE**
Wed-Sun 9-5
Mon & Tues

PLEASE LOCK YOUR VEHICLE
PLEASE TAKE PURSES AND OTHER
VALUABLES WITH YOU









PRESTON JACKSON
11320 N. Hickory Woods Court
Dunlap, Illinois 61525

pjacks@saic.edu PJMJ0001@aol.com Mobile# 309-657-6808
www.prestonjacksonart.com www.artic.edu/~pjacks

Preliminary Concept for King Park Public Art Project

CONCEPT

My concept for the Martin Luther King, Jr. Park sculpture project deals with American history during and after the civil rights movement, showing Dr. King's involvement at various events and locations, acknowledging his legacy. Although hopefully everyone knows of Dr. King, this is an opportunity to educate the public regarding his activities and concepts, and to honor those who worked with him.

My intent is to maintain an overall simple design form that is esthetically interesting and clearly presented to the observer. The story of Dr. King and the historical importance of his work are first and foremost--public art should be a vehicle for our history which will help people understand both our past and the related social issues.

I propose that the sculpture be a cast bronze relief with an array of figural images set into a stainless steel structure. The images I have selected to speak of the life and work of Dr. King are listed here, and indicated on my drawings. The drawings show examples of how they will appear in the finished piece. The sculpture will consist of two main stainless steel forms jutting upward at different angles, supporting each other, with a middle brace which strengthens the piece and creates interesting light and shadow effects. The images at the upper portion of the sculpture penetrate downward to the base, keeping the entire work as one structure. The slight twist to the whole piece makes it multi-faceted.

THEMES

An important component will be a fabricated stainless steel image of the Edmund Pettus Bridge, the site of events leading up to the signing of the Voting Rights Act of 1965 by President Johnson. The bridge was designated a National Historic Landmark this year, and is widely viewed as a symbol of the Civil Rights movement. My use of the bridge as the basic design element is to be interpreted both literally and symbolically. The sculpture will feature other identifiable images, such as the buses from the Montgomery bus boycott, the Birmingham Sixteenth Street Baptist Church, the Lorraine Motel where Dr. King was killed, a representation of his Nobel Peace Prize in cast bronze, and other images. Marches, voting drives and other events will be shown in bronze relief.

MATERIALS

The imagery of the piece will be depicted in Grade 304 stainless steel and cast silicon bronze, both highly durable, low-maintenance materials. For this piece, I would recommend a medium patina for the bronze, which would be most weather-resistant, which will allow the piece will develop a natural patination.

SAFETY & INSTALLATION

Safety, of course, is primary concern. The sculpture will have no sharp edges and there will be no weak linear areas that could be bent or broken. Installation would be technically simple, with the sculpture bolted directly to a concrete pad which would stabilize the piece.

SIZE & ACCESSIBILITY

This sculpture, approximately twelve feet in height, will be visible from a distance, and as the viewer approaches the detail elements will be revealed. Images will be created so that they are easily visible from the base of the sculpture. In my view, public art should be on the level of fine art, and yet remain highly accessible to individuals from all backgrounds, including children. The narrative nature of the sculpture will make it interesting to both children and adults, telling the story of Dr. King's life and legacy.

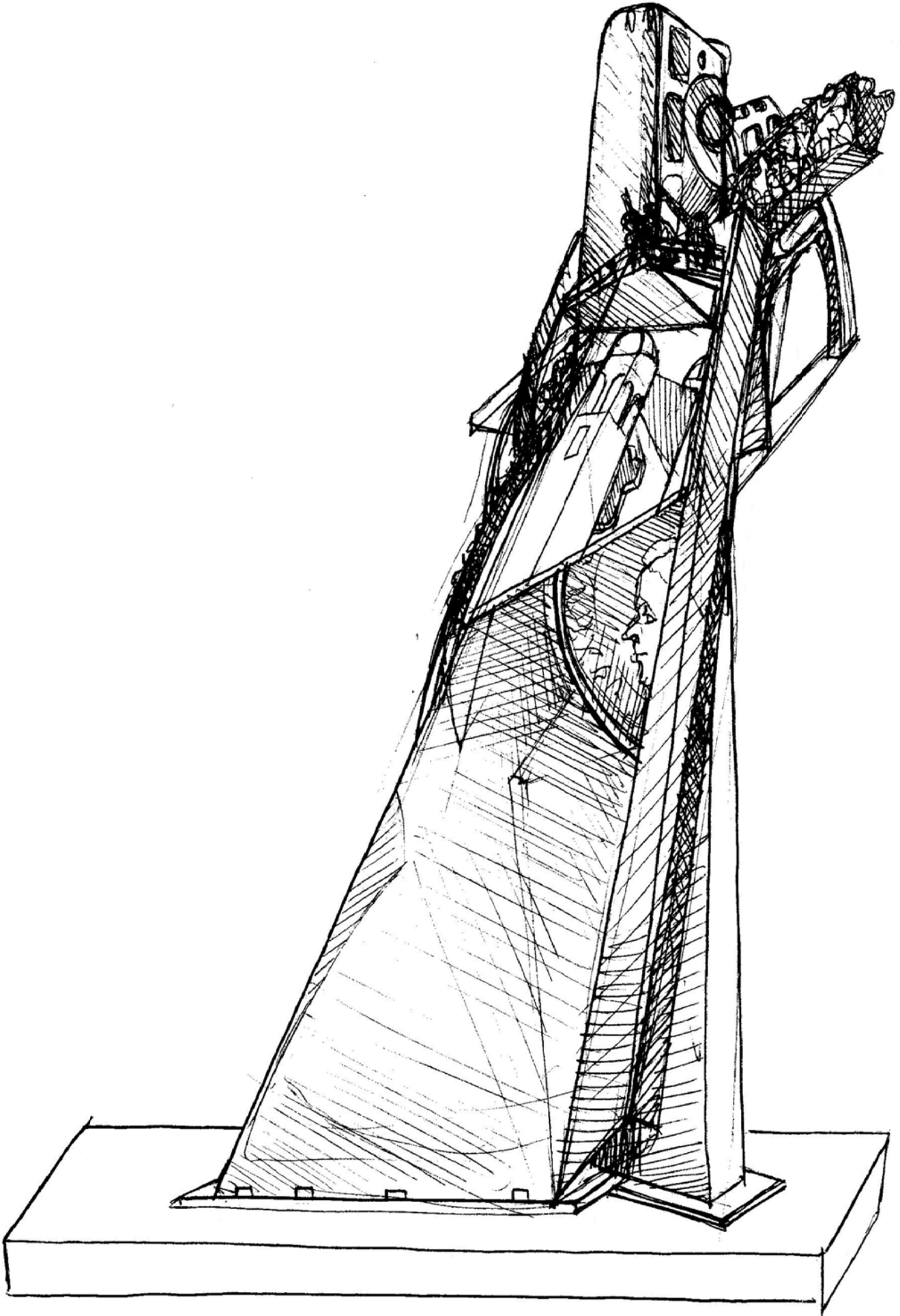

Detail View King Park Art Proposal Preston Jackson

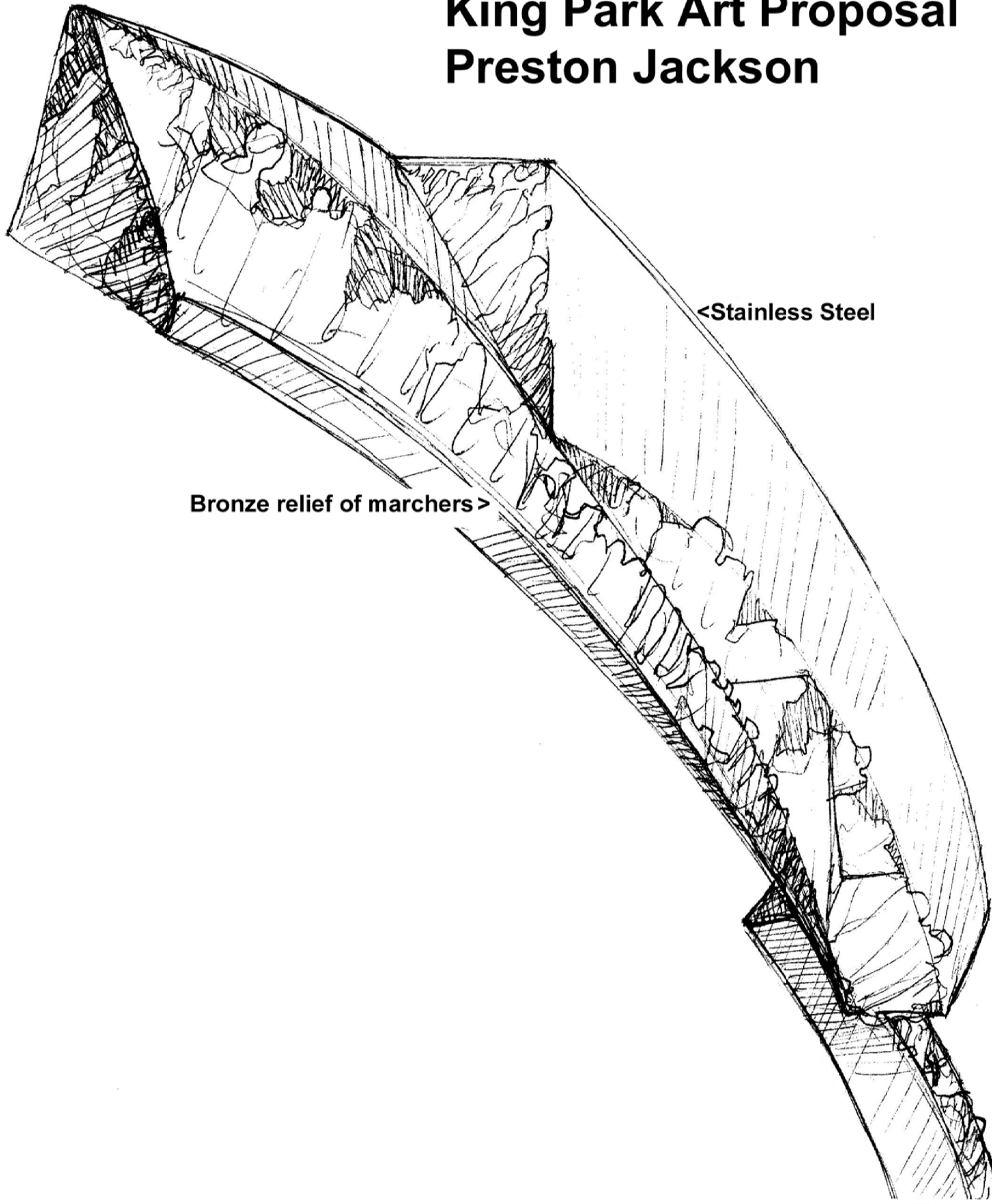

<Stainless Steel

Bronze relief of marchers >

Bronze reliefs of marches, sections scattered through >

Lorraine Motel Balcony >
Cast Bronze

The bottom of the piece >
shows structural steel
work and rivets which
reference the Pettus
Bridge, which are
evident as the viewer
approaches

Revised View King Park Art Proposal Preston Jackson

This view shows the piece
as it looks from a distance.

< The canopy of the Pettus Bridge--
looking upward, the viewer sees the
sky as if actually entering the bridge

< More bronze reliefs of demonstrations

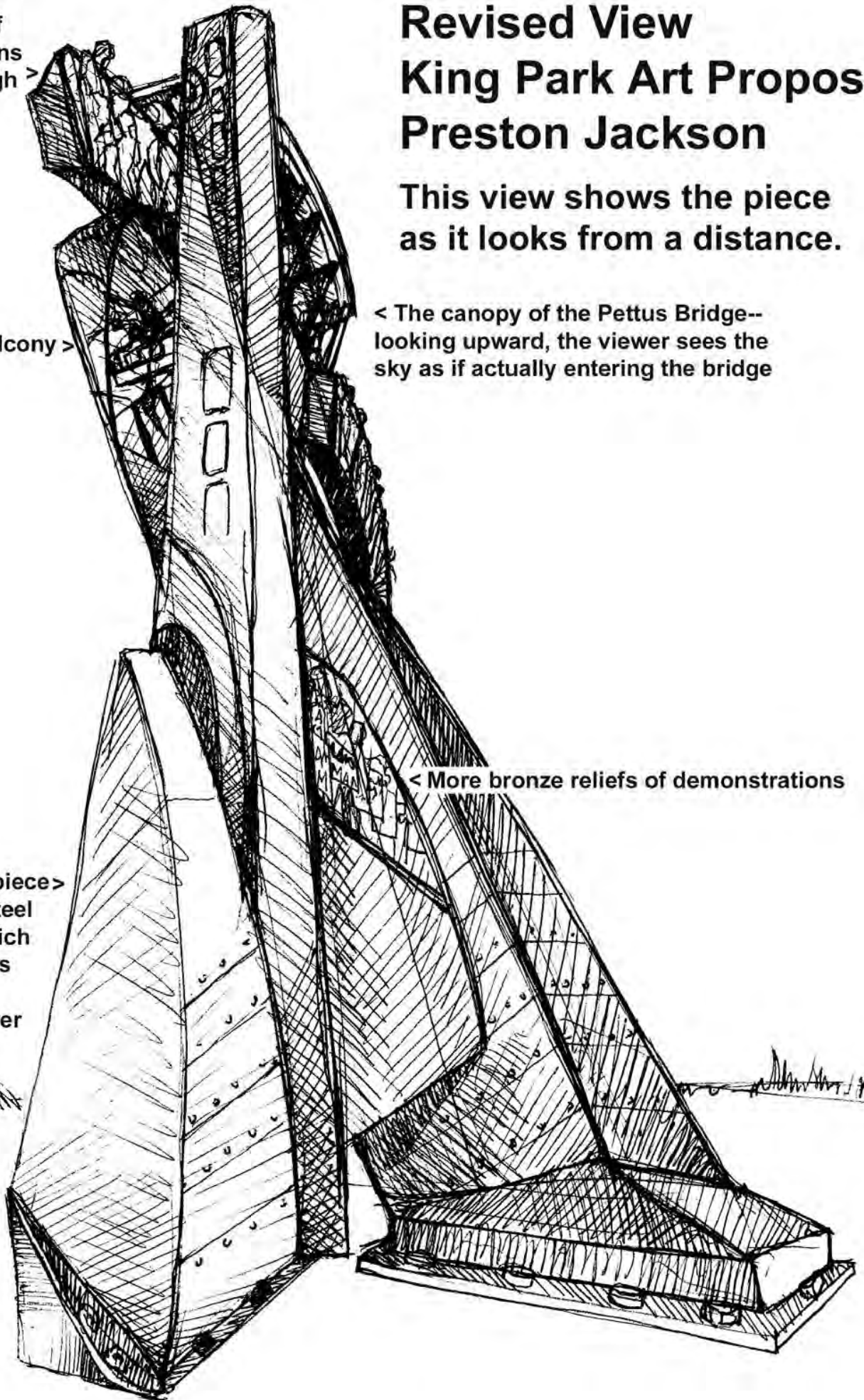

View 1 King Art Proposal Preston Jackson

^
Bronze cast figures
as central theme

<
Bus-like vehicle extending to the ground

>
Representation of
Pettus Bridge

<
Entrance to
Pettus Bridge

>
Cut out stainless plate shapes

<
Space beneath middle brace
captures and bends light

Simple poured concrete base

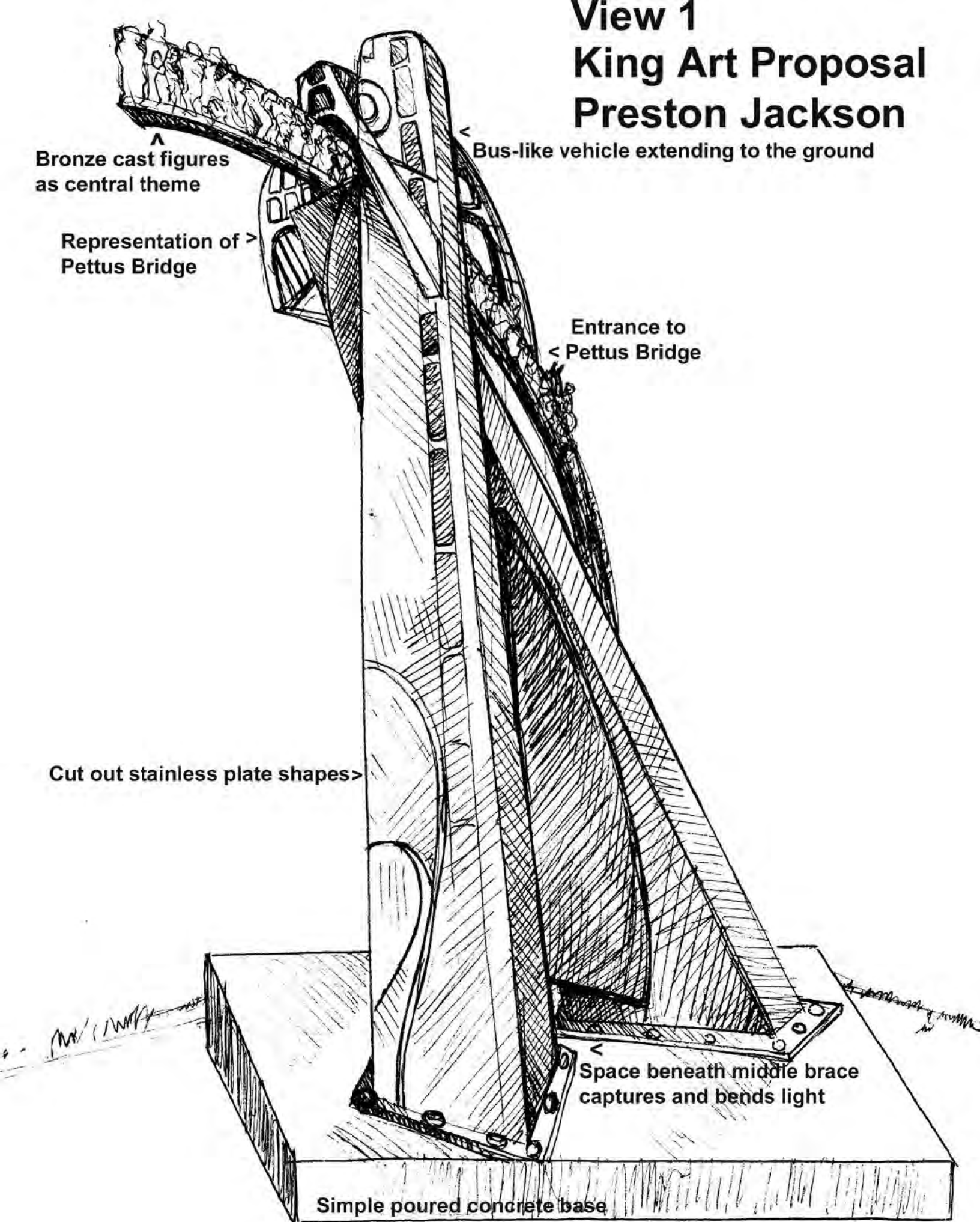

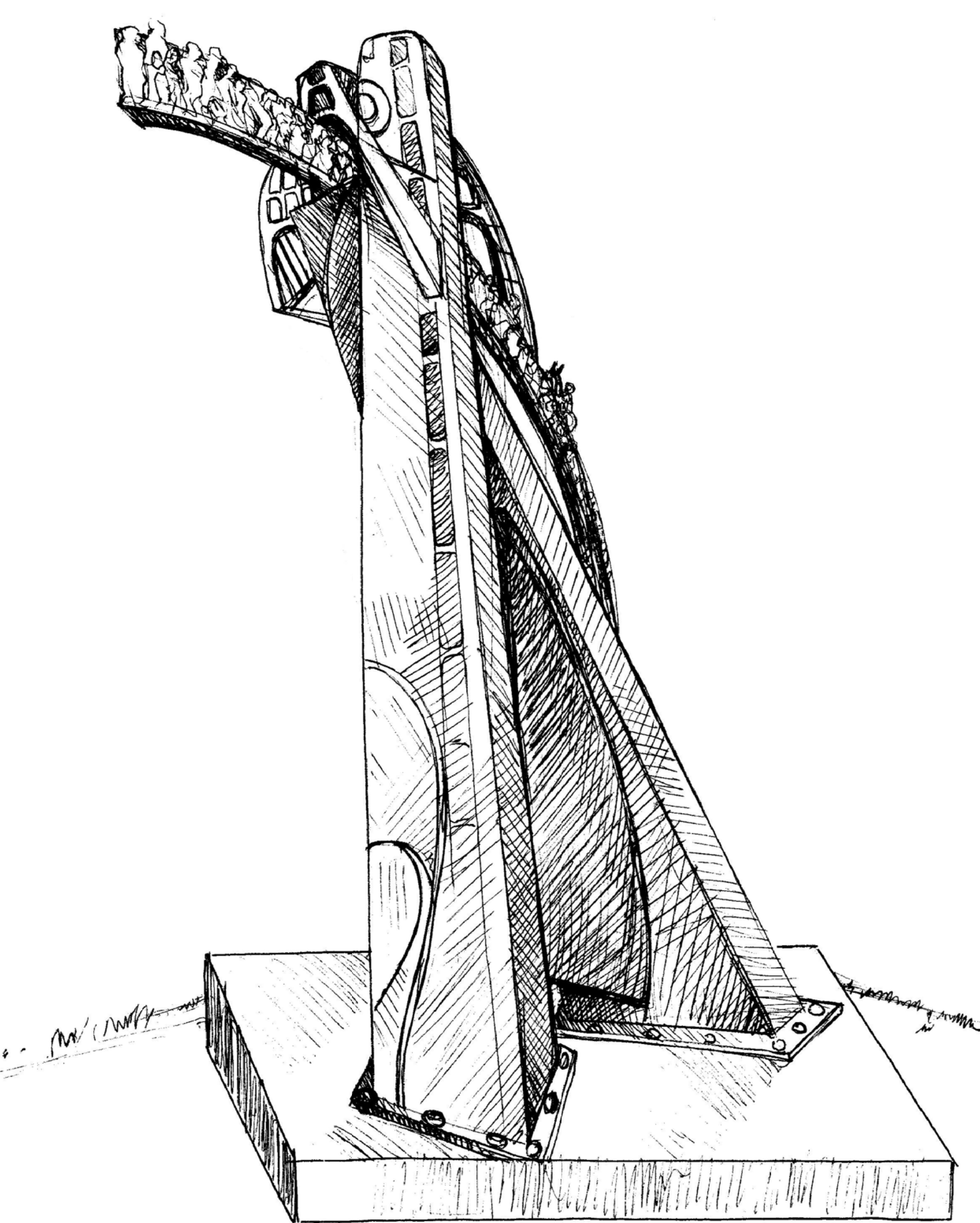

View 2

King Art Proposal

Preston Jackson

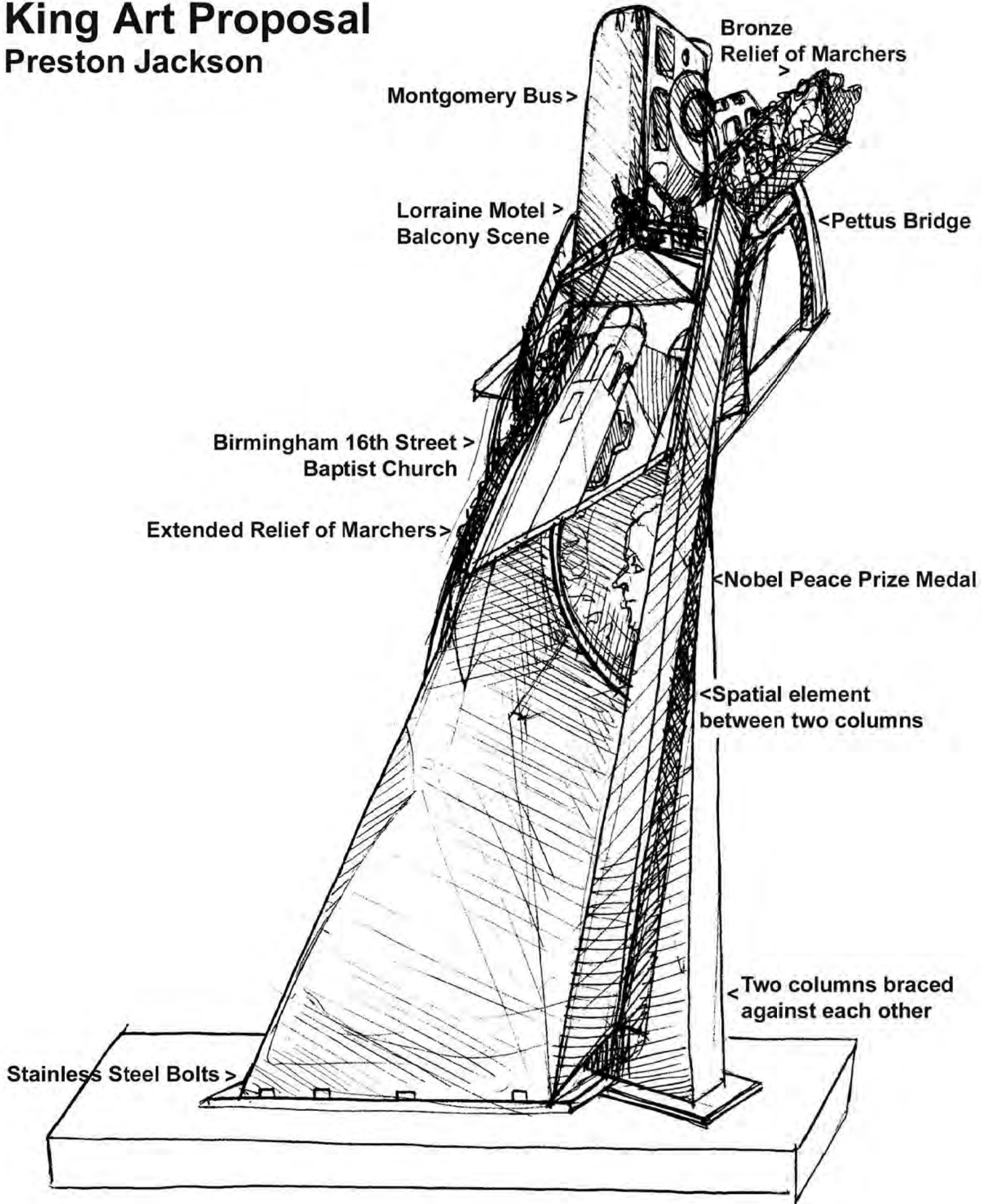

King Park Project Details

Preston Jackson

Fabrication Schedule

July-August	Begin stainless steel fabrication and wax modeling for bronze.
Mid August	Complete waxes for casting by foundry, continue stainless steel fabrication. Photographs of the project will be provided; visits to the studio to view progress are invited.
September	Waxes to foundry for casting in bronze.
November	Complete fabrication, including fastening bronze reliefs to stainless sculpture.
December	Delivery of completed piece to Urbana

Installation

A crane or similar device will be required to place the sculpture. Installation will be done by bolting the piece to the prepared concrete pad with one-inch stainless steel expansion bolts as shown in the attached drawings.

Maintenance Requirements

The imagery of the piece will be depicted in stainless steel and cast silicon bronze, both highly durable, low-maintenance materials. The stainless steel portions require only periodic cleaning with plain water or water with mild soap to remove surface grime.

For this piece, I will use a medium patina for the bronze, which would be most weather-resistant, which will allow the piece to develop a natural greenish-black patination. The only maintenance required for the bronze is the application of paste wax every 5-10 years.

Preston Jackson

**PROPOSED BUDGET
City of Urbana King Park Project**

**Sculpture Dimensions:
12' height by 6' length by 4' depth
Cast Bronze & Stainless Steel**

Artist's Fee, Modeling, Armature Fabrication	\$ 14,500.
Foundry Casting, Including Materials and Patination	\$ 20,000.
Stainless Steel Material and Welding Supplies	\$ 8,000.
Stainless Cutting, Welding and Fitting	\$ 15,000.
Administrative Services, Insurance, Research & Project Coordination	\$ 3,000.
Wax and other Materials	\$ 2,500.
Studio Labor	\$ 2,000.
Transportation to Foundry and Delivery to Site	\$ 4,000.
Installation N/A	____0____
TOTAL	\$ 69,000.

King Park Sculpture Preston Jackson

Scored separation
lines with
simulated rivets

Stainless Steel Sheet

Stainless
Bolts
and
Washers

Expansion
Sleeves

Drilled Hole
In Concrete

Concrete Pad

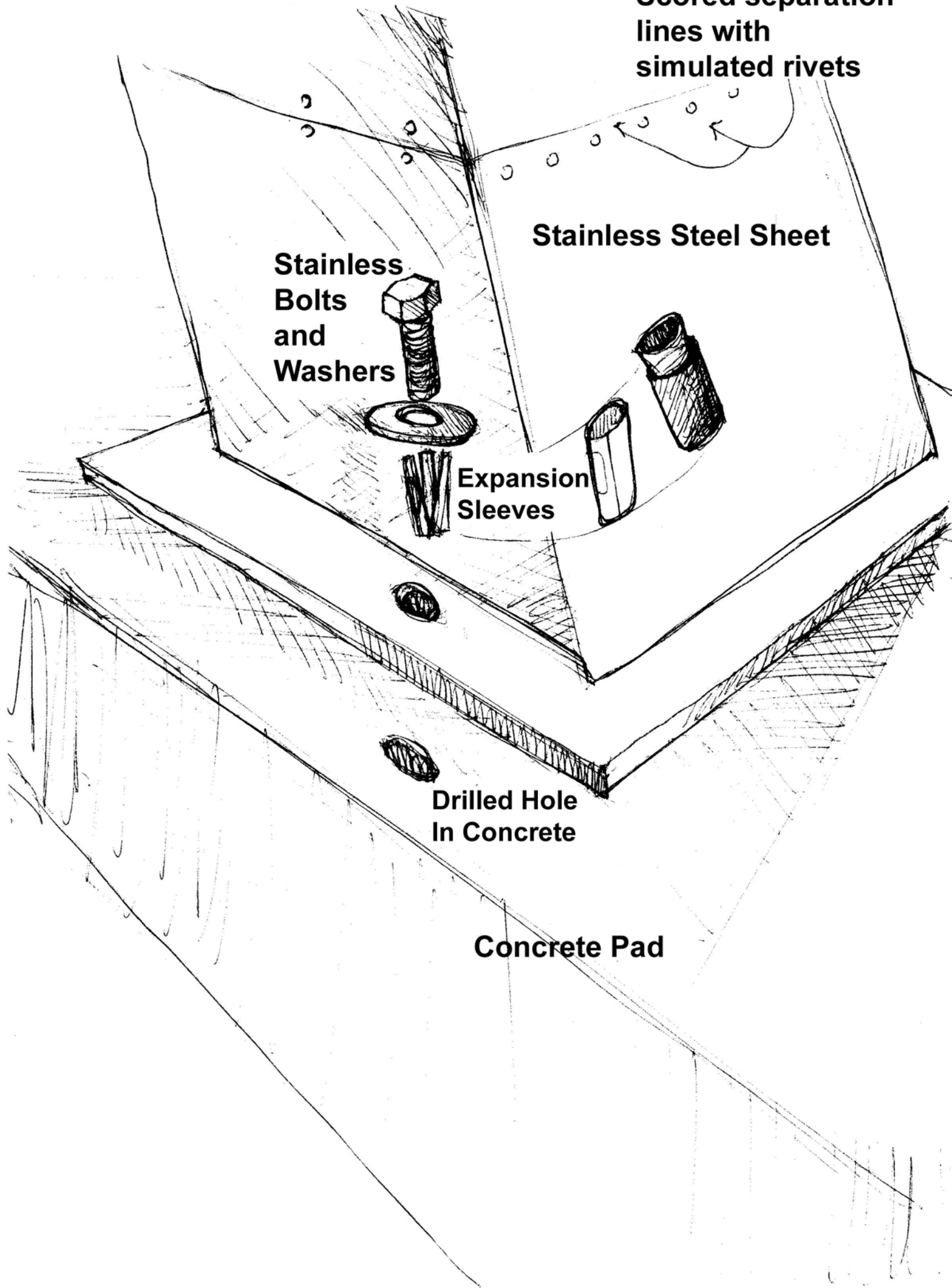

King Park Sculpture

Preston Jackson

Attaching Sculpture to Concrete Pad

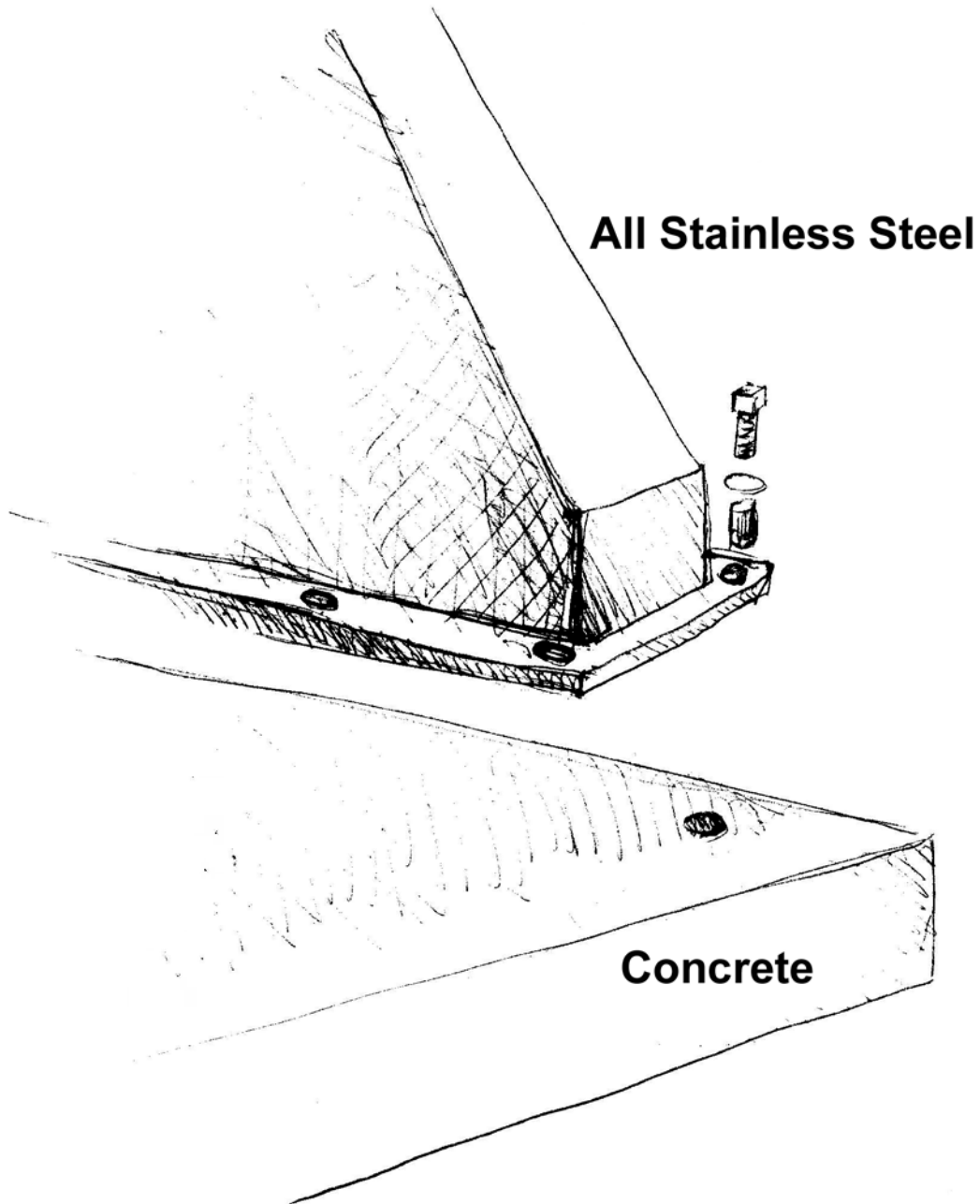

**King Park Sculpture
Preston Jackson**

**Example of bronze and stainless
fabrication technique**

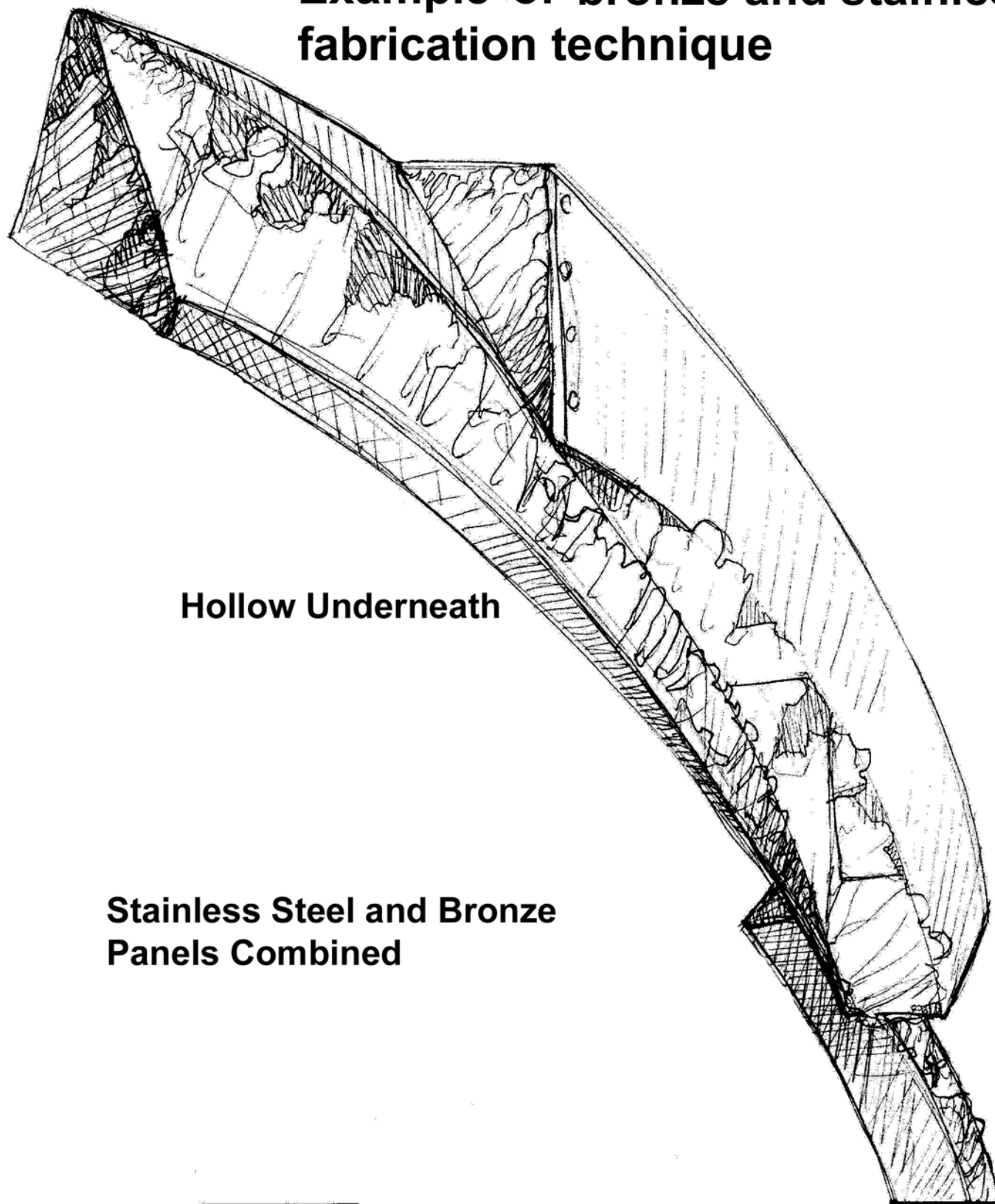

Hollow Underneath

**Stainless Steel and Bronze
Panels Combined**

**King Park Sculpture
Preston Jackson**

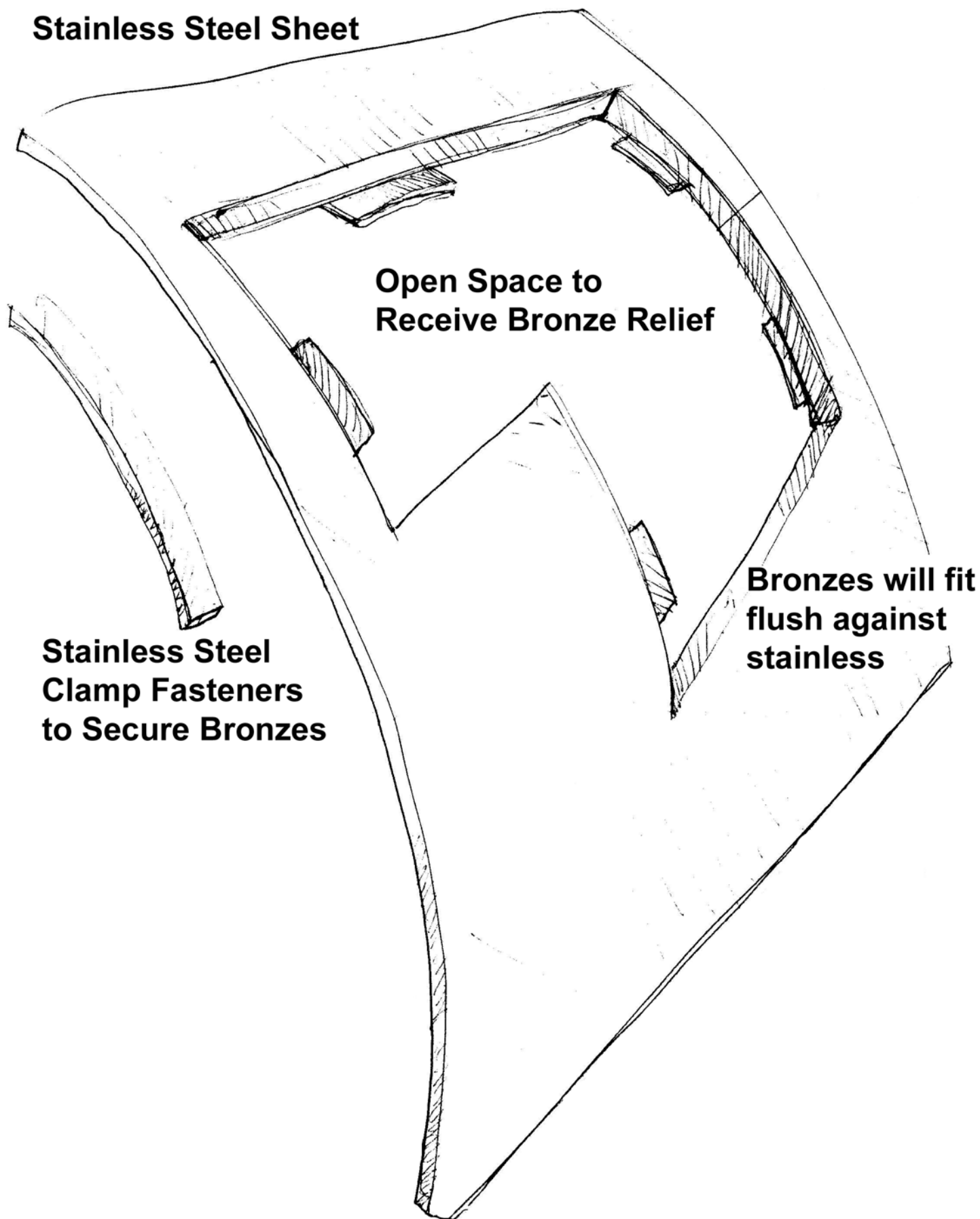

Stainless Steel Sheet

**Open Space to
Receive Bronze Relief**

**Stainless Steel
Clamp Fasteners
to Secure Bronzes**

**Bronzes will fit
flush against
stainless**

King Park Sculpture Preston Jackson

Approximate Dimensions

12 feet in height

6 feet in width

2-3 feet in depth

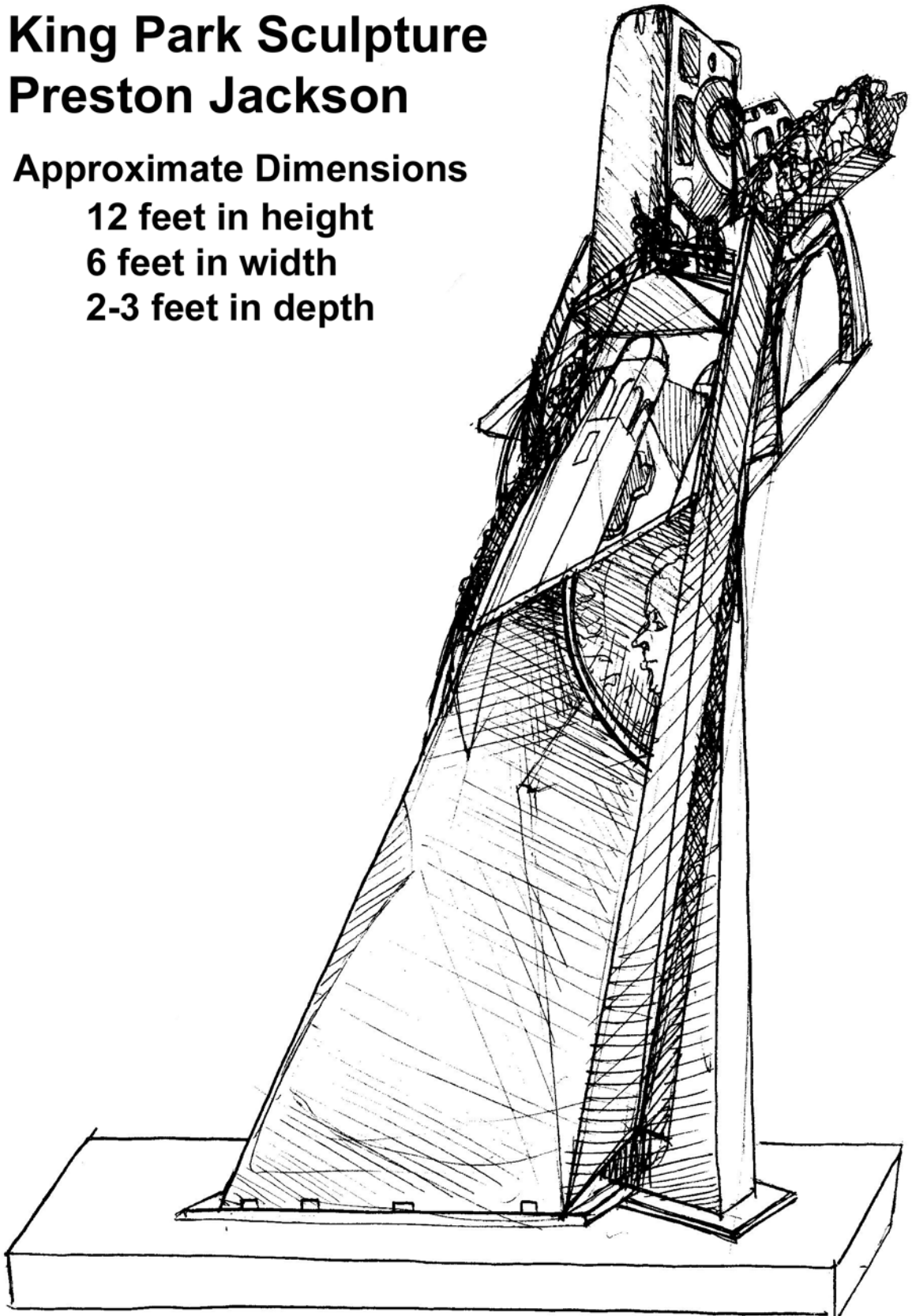

King Park Sculpture Preston Jackson

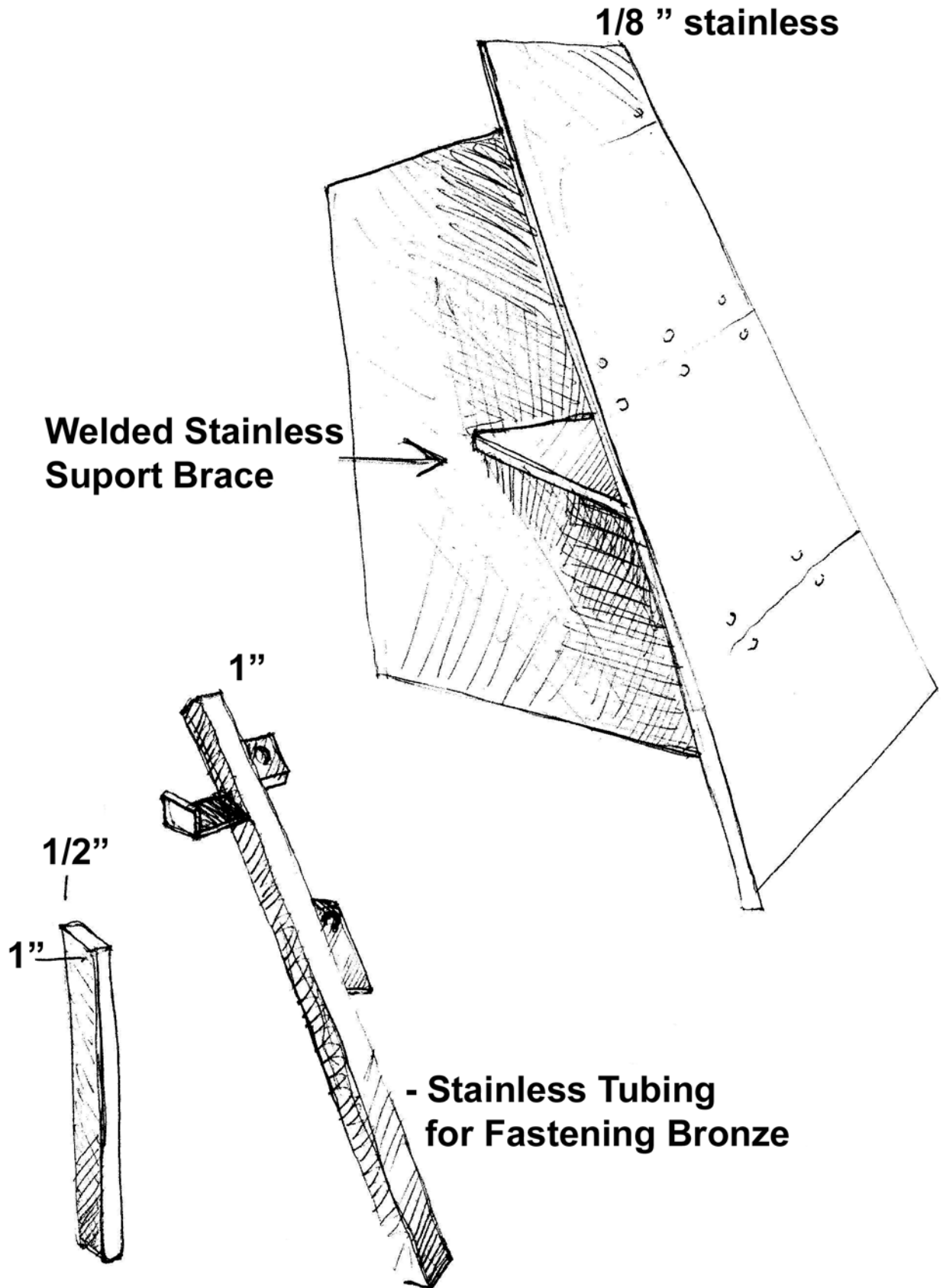

MINUTES OF A REGULAR MEETING

URBANA PUBLIC ARTS COMMISSION

DRAFT

DATE: June 11, 2013

TIME: 4:30 p.m.

PLACE: City Council Chambers, Urbana City Building, 400 South Vine Street, Urbana, Illinois

MEMBERS PRESENT: Greg Chew, Kevin Hamilton, Eric Jakobsson, John Morrison, Pat Sammann, Ginny Waaler, Mary-Ann Winkelmes

MEMBERS ABSENT: Ilona Matkovski

STAFF PRESENT: Christina McClelland, Public Arts Coordinator; Sukiya J. Reid, Recording Secretary

OTHERS PRESENT: Martha Churukian, Kate Insolia, Sheri Langendorf, Jonah Weisskopf, Kelly White

1. CALL TO ORDER, ROLL CALL AND DECLARATION OF QUORUM

The Urbana Public Arts Commission was called to order at 4:31 p.m. by Ms. Sammann. Christina McClelland took roll and a quorum was declared present.

2. CHANGES TO AGENDA

There were none.

3. APPROVAL OF MINUTES OF PREVIOUS MEETING

The minutes of the May 14, 2013 meeting were reviewed by the Commission. With no changes proposed, Ms. Winkelmes made a motion to approve the minutes. Ms. Winkelmes seconded the motion. All Commission members present were in favor of approval and the minutes were unanimously approved as presented.

4. PUBLIC INPUT

There was none.

6. OLD BUSINESS

- **King Park Public Art Project Addendum**

Ms. Sammann introduced this agenda item. Ms. McClelland gave an update on the progress of the King Park Public Art Project. She stated that Preston Jackson had submitted a final design, which was reviewed by a few employees of the Urbana Park District, as well as City Staff. Ms. McClelland reported that the Urbana Park District had committed to assisting with installation and site preparation for the project, which is an in-kind contribution of about \$10,000. That gesture would allow for the budget of this project to be used more for the fabrication of the larger piece. She stated that after reviewing the final design, the Community Development Services Director approved it, and Staff has worked with Mr. Jackson to negotiate an addendum which commissions the piece. The addendum agrees that the artist will fabricate the sculpture as outlined in the final design, and that the artist will deliver the artwork to the City. It also includes a payment schedule, warrants that the artwork shall be a unique and original project, and that the title of the artwork shall be transferred from the artist to the City. Ms. McClelland stated that Staff recommends that the Commission approve Exhibit C, the Addendum to the King Park Public Art Design Services Agreement. Upon this approval, the addendum would be presented to the Urbana City Council for final approval on June 17, 2013. Comments and questions from the Commission were addressed. Following discussion, Mr. Morrison made a motion to approve the King Park Public Art Project Addendum. Mr. Chew seconded the motion. With no further comments or questions from the Commission, Ms. Sammann called for a voice vote. All Commission members were in favor of approval and the motion carried unanimously.